

HEAVY DUTY BASE MACHINE FOR FOUNDATION WORK BM800

KOBELCO

Max. Lifting Capacity: 90 Metric Tons at 3.7 Meters

Max. Boom Length: 57.91 Meters

Specifications

- A mega-powered crane equipped with precision control capability.
- A mechatronic-micro control system allows precise diaphragm wall construction with a multi-axle rotary excavator.
- Automatic constant speed mode lowers excavator at constant speed regardless of changes in ground resistance. (opt.)
- Automatic constant load mode prevents damage to cutters in hard ground. (opt.)
- Powerful winch first layer maximum line pull of 25 tons, and wide, large-diameter drum with maximum rope capacity of 37 m at first layer.
- Maximum line speed of 100 m/min for main and auxiliary winches.
- Extra hydraulic outlets provided to power additional foundation construction machinery.

General Dimensions

Unit: mm

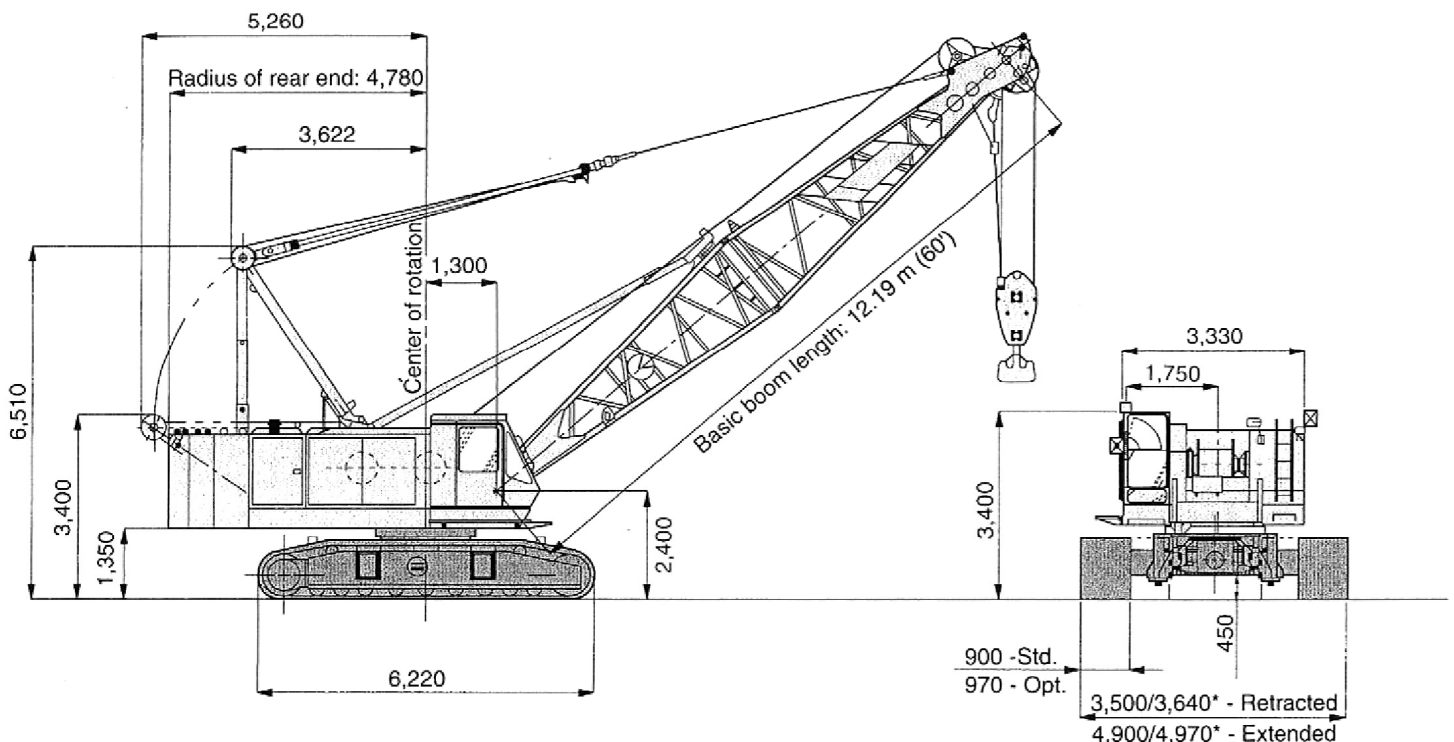

Specifications

Upper machinery



Power plant (Standard)

Model Cummins NTA855-C450
Type Water-cooled, direct fuel injection, aftercooled turbo

No. of cylinder 6
Bore and stroke 140 mm x 152 mm (5.5" x 6.0")
Displacement 14.0 liters
Rated power 420 PS (309 kW) at 2,000 rpm (SAE J1349)
Max. torque 187 kg-m at 1,400 rpm (SAE J1349)
Cooling system Liquid, recirculating bypass
Starter 24 V, 7.2 kW
Generator 24 V, 1.7 kW
Cycles 4
Radiator Plate fin type core, thermostatically controlled
Air cleaner Dry type with replaceable paper element
Fuel tank capacity 600 liters
Batteries Two 12V, 200A-hr capacity batteries, series connected
Fuel consumption (at 1,700 rpm) 152 g/PS-h

Power plant (Optional)

Model Mitsubishi 6D22-TC
Type Water-cooled, direct fuel injection, intercooled turbo

No. of cylinder 6
Bore and stroke 130 mm x 140 mm (5.1" x 5.5")
Displacement 11.149 liters
Rated power 294 PS (216 kW) at 2,000 rpm (JIS D1005)
Max. torque 117 kg-m at 1,400 rpm (JIS D1005)
Cooling system Liquid, recirculating bypass
Starter 24 V, 5.5kW
Generator 24 V, 1.5kW
Cycles 4
Radiator Plate fin type core, thermostatically controlled
Air cleaner Dry type with replaceable paper element
Fuel tank capacity 600 liters
Batteries Two 12V, 200A-hr capacity batteries, series connected
Fuel consumption (at 1,500 rpm) 154 g/PS-h



Hydraulic system

Pumps: All four variable displacement pumps are driven by heavy-duty pump drive. One of these pumps is used in the right propel circuit and hook, boom hoist circuit. Another is used in the left propel circuit and hook hoist circuit, and can accommodate an optional third hoist circuit. The third variable displacement pump is used in the swing circuit, and can accommodate the hydraulic outlet circuit. The fourth variable displacement pump is used in the hydraulic

outlet circuit. In addition, one gear pumps are used in the control system and auxiliary equipment. One of these serves the clutch and brakes.

Control: Full-flow hydraulic control system for infinitely variable pressure to front and rear drums, boom hoist brakes and clutches. Controls respond instantly to the touch, delivering smooth function operation.

Max. relief valve pressure:

Load hoist, boom hoist and propel system 280 kg/cm² (4,000 psi)

Swing system 280 kg/cm² (4,000 psi)

Control system 60 kg/cm² (850 psi)

Reservoir capacity: 600 liters

Cooling: Oil-to-air heat exchanger

Filtration: Full-flow and bypass type with replaceable

Hydraulic outlet: Hydraulic power outlet system is provided for foundation work, such as diaphragm wall bucket, oscillation works, and etc.

No. of outlet	Max. oil flow	Max hydraulic pressure
1	320 liters/min	280 kg/cm ²
2	420 liters/min	280 kg/cm ²
3	31 liters/min	175 kg/cm ²

Electrical system: All wiring corded for easy servicing, individual fused branch circuits.



Boom hoisting system

Powered by a hydraulic axial piston motor through a planetary reducer.

Brake: A spring-set, hydraulically released multiple-disc brake is mounted on the boom hoist motor and operated through a counter-balance valve. Safety pawls (external ratchet) are fitted for locking the drum.

Drum: Single drum, grooved for 18 mm dia. wire rope.

Line speed: Single line on first drum layer

Hoisting (max.) 50m/min

Lowering (max.) 50m/min

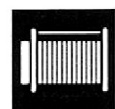

Load hoist system

Powered by a hydraulic axial piston motor, driven through a planetary reducer.

Clutches: Internally expanding band clutches.

950 mm dia. x 125 mm wide

Brakes: Externally contracting band brakes, each using positive and negative actuation. 1,150 mm dia. x 150 mm wide with additional spring set hydraulically released brake.

Safety pawls (external ratchet) are fitted for locking the drums. Both positive and negative brake systems are available. Air cooling fins mounted on brake drum.

Drums: (front and rear): 594 mm P.C.D. x 606 mm wide

drums, each grooved for 28 mm wire rope.

Rope capacity of 205 m working length and 324 m storage length.

Line pull: Single line pull at the first drum layer

Standard winch;

Max. line pull 25 tons
 Rated line pull 12.5 tons

High-speed winch;

Max. line pull 20 tons
 Rated line pull 12.5 tons

Line speed: Single line on the first drum layer

Standard winch;

Hoisting 80/50, 40/25 m/min
 Lowering 80/60, 40/25 m/min

High-speed winch;

Hoisting 100/60, 50/30 m/min
 Lowering 100/60, 50/30 m/min



Swing system

Swing unit: Powered by hydraulic axial piston motor driving spur gears through planetary reducers, the swing system provides 360°

rotation.

Swing speed 2.7 rpm

Swing brakes: A spring-set, hydraulically released multiple-disc brake is mounted on swing motor.

Swing circle: Single-row ball bearing with an integral internally cut swing gear.

Swing lock: Four position pin-hole lock (manually engaged)



Operator's cab

Totally enclosed, full-vision cab fitted with safety glass and a sliding front window. A fully adjustable, high-backed seat permits operators to set their ideal working position. A signal horn, cigarette lighter, and windshield wiper are standard features.

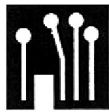

Controls

In front of the operator are foot pedals for front and rear drum brakes. At the operator's right are console-mounted adjustable

short levers for front and rear drum control, boom hoist control lever and positive/negative break select switch for front and rear drum brakes, and creep speed control for hoist and propel. Beside the operator's seat on the right are two short levers for propel control. At the operator's left are: a console-mounted swing lever, an optional third drum control lever, and front and rear drum pawl control switches; switches for ignition, engine stop, low and high speed control for front drum, rear drum and propel. A swing brake switch and a signal horn button are on the swing lever.

Lights: Two front flood lights, one cab inside light, three machinery cab inside lights, and one trouble light.

Gauges: Fuel, water temperature for engine, hydraulic oil temperature, hour meter and tachometer.

Warning lamps: Engine oil pressure, hydraulic oil pressure, battery charge, air cleaner and engine oil filter.

Safety devices: Hook over-hoist alarm and shut-off

switch, boom over-hoist limit switch, boom angle indicator, signal horn, boom hoist and front and rear drum locks, swing lock, boom back stop, hook safety latch on hook blocks and optional load moment limiters (overload protection device) are provided.



Gantry

Folding type, fitted with sheave frame for boom hoist reeving, lowers toward rear onto cab roof. Hydraulic lift is standard. Full up, full down positions with linkage.

Counterweight

Two-piece, mounted behind the machinery compartment
 Total weight 26,700 kg



Tools

Tool set and accessories for routine machine maintenance are provided.

Lower machinery

Carbody: Steel-welded carbody with an integral seat for axles.

Crawler: Crawler assemblies designed with a quick disconnect feature that allows complete individual removal from the axles. Crawler belt tension is maintained by hydraulic jack force on the track-adjusting bearing block.

Crawler drive: Independent hydraulic propel drive is built into each side frame, each with a hydraulic motor propelling a driving tumbler through a planetary gear box.

Crawler brakes: Spring-set, hydraulically released multiple-disc parking brakes are built into each propel drive.

Steering mechanism: A hydraulic propel system provides both skid steering (driving one track only) and counter-rotating steering (driving tracks in opposite directions).

Track rollers: 9 lower rollers and 2 upper rollers are fitted to each side frame, sealed and maintenance-free.

Shoes:

Number 58 each side
 Standard flat shoe width 900 mm
 Optional wide shoe width 970 mm

Max. travel speed:

High range 1.4 km/h
 Low range 0.9 km/h

Max. gradeability: 30%

Trans-Lifter : Trans-Lifter system allows quick and easy crawler side frame removal and replacement. 4 vertical cylinders lift the basic machine. 2 horizontal cylinders facilitate side frames for removal or replacement.

Crane attachment



Boom:

Welded lattice construction using tubular, high-tensile steel cords with pin connections between sections.

Max. lifting capacity	90,000 kg
Basic boom length	12.19 m (40')
Max. boom length	57.91 m (190')



Hook blocks

A range of hook blocks can be specified, each with a safety latch.

Lifting capacity	90 tons	50 tons	30 tons	12.5 tons ball hook
No. of sheaves	4	3	1	0
Weight (kg)	1,150	850	700	300

Diameter of wire ropes

Standard:

Hook hoist 28 mm
 Boom hoist (12-part line) 18 mm
 Boom pendants (2-part line) 32 mm

Optional:

Aux. hoist 28 mm

Boom hoist reeving: 12 parts of 18 mm dia. wire rope

Boom backstops: recommended for all boom lengths

Line pull

(for crane, clamshell, diaphragm wall bucket)

	Max. permissible	Max. available	
		Standard	High-speed
Front:	12,500 kg	25,000 kg	20,000 kg
Rear:	12,500 kg	25,000 kg	20,000 kg



Weight

Operating weight:

Approx. 86,000 kg
 (including 12.19 m (40 ft) boom and 90 ton hook block with standard engine)

Ground pressure: 0.84 kg/cm² with 900 mm shoes

A Versatile Base Machine for a Wide Range of Applications!

Hydraulic Diaphragm Wall Bucket

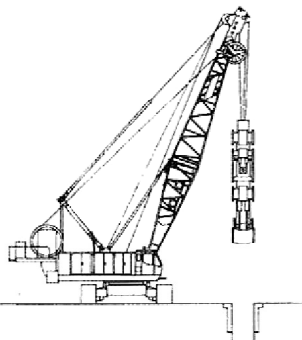

Casing Oscillator Casing Rotator

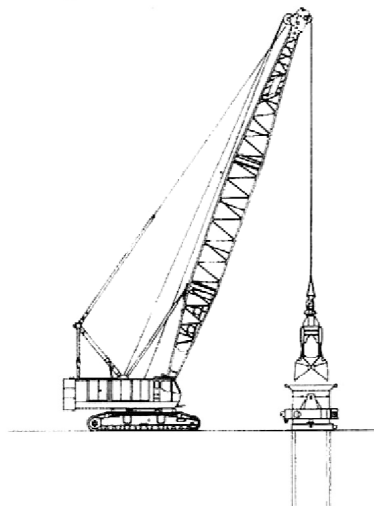

Trenching mill

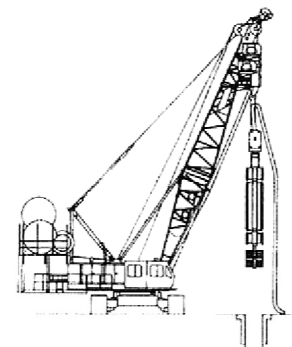

For specific information on the use of diaphragm wall bucket, casing oscillator, casing rotator and trenching mill, please contact your nearest KOBELCO distributor.

Notes:

- Working radius is the horizontal from the center of rotation through the center of gravity of load.
- Ratings do not exceed 78% of tipping load on the hard horizontal ground and includes weight of hook block, slings and all other load handling accessories from main boom rating shown.
- Ratings shown are based on freely suspended load and make no allowance for such factors as wind effect on lifted load, out-of-level ground conditions, operating speeds or any other condition that could be detrimental to the safe operation of this equipment.
- No operation is possible in the range indicated by blank spaces in the chart.
- The actual hoistable loads using main boom must be calculated by deducting the weight of main hook, slings and all other load handling accessories etc. from the ratings shown.
- Configurations of main boom and guy cables installations must be arranged as per the instruction of the owner and operator's manual, to be provided with machine.
- Hook block weight and capacity (metric ton).

Capacity of hook	90 ton	50 ton	30 ton	12.5 ton (ball-hook)
Weight (metric ton)	1.15	0.85	0.7	0.3

8. Max. hoisting load

No. of parts of line	1	2	3	4	5
Max. load (metric ton)	12.5	24.0	36.0	48.0	60.0
No. of parts of line	6	7	8		
Max. load (metric ton)	71.0	82.0	90.0		

- Auxiliary sheave rating is determined by deducting weight of auxiliary sheave (260kg) and weight of main hook from main boom rating. It must not exceed 12.5 tons.
- Actual hoistable loads using auxiliary sheave can be calculated by deducting weight of 12.5 ton ball-hook and weight of slings and other loads handling accessories from auxiliary sheave rating.
- Main boom rating when it is equipped with auxiliary sheave is determined by deducting the weight of the auxiliary sheave (260kg) from the rating for main boom without auxiliary sheave. When using main boom equipped with a ball-hook, weight of ball-hook (300kg) must also be deducted.
- Actual hoistable load with main boom being equipped with auxiliary sheave can be calculated by deducting weight of hook, and any other slings and accessories from the main boom rating with auxiliary sheave.
- Auxiliary sheave can be attached to boom between 12.19 m and 54.86 m in length.
- Maximum working radius with auxiliary sheave attached must not exceed maximum working radius of main boom. Minimum working radius is working radius of auxiliary sheave at boom angle for minimum working radius of boom.
- Do not use hook on main boom and hook on auxiliary sheave simultaneously.
- Boom should in principle be erected over front of crawlers. For boom lengths shown in following table, steel plates must be used under front end of crawlers when erecting/lowering boom.

Equipment	Boom length
Boom only	57.91 m

Working Ranges

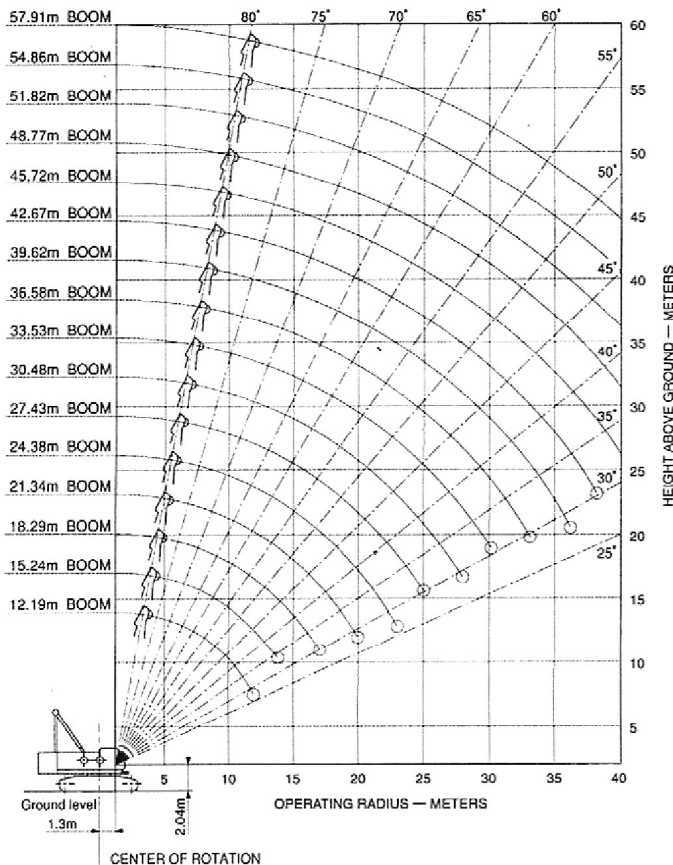

Boom Lifting Capacities

BM800

Unit: metric ton

Rated loads in metric tons for 360° working area

Crawler fully extended

Working radius m	Boom length m (ft)																Working radius m	
	12.19 (40)	15.24 (50)	18.29 (60)	21.34 (70)	24.38 (80)	27.43 (90)	30.48 (100)	33.53 (110)	36.58 (120)	39.62 (130)	42.67 (140)	45.72 (150)	48.77 (160)	51.82 (170)	54.86 (180)	57.91 (190)		
3.7	90.0																	3.7
5	64.7	64.5	64.3															5
6	52.9	52.8	52.5	52.5	52.3	6.5m /46.3												6
7	41.9	41.7	41.5	41.4	41.2	41.2	41.0	7.5m /37.5										7
8	34.5	34.4	34.1	34.1	33.9	33.8	33.6	33.6	33.5	8.5m /30.0								8
9	29.3	29.2	28.9	28.8	28.7	28.6	28.4	28.3	28.3	28.1	28.1	9.6m /25.7						9
10	25.5	25.3	25.0	24.9	24.7	24.7	24.5	24.4	24.3	24.2	24.1	24.0	10.1m /23.7	10.6m /20.0				10
12	18.5	19.8	19.6	19.5	19.3	19.2	19.0	18.9	18.9	18.7	18.6	18.5	18.4	18.2	18.2	17.3		12
14		16.3	16.0	15.9	15.7	15.6	15.4	15.3	15.2	15.1	15.0	14.8	14.7	14.5	14.5	14.3		14
16			13.4	13.3	13.1	13.0	12.8	12.7	12.6	12.5	12.4	12.3	12.1	11.9	11.9	11.7		16
18			17m /12.3	11.4	11.2	11.1	10.9	10.8	10.7	10.6	10.5	10.3	10.2	10.0	10.0	9.8		18
20				10.0	9.7	9.6	9.4	9.3	9.2	9.1	9.0	8.8	8.7	8.5	8.4	8.3		20
22					8.5	8.5	8.2	8.1	8.0	7.9	7.8	7.6	7.5	7.3	7.2	7.1		22
24					23m /8.1	7.5	7.2	7.1	7.0	6.9	6.8	6.6	6.5	6.3	6.3	6.1		24
26						25m /7.0	6.4	6.3	6.2	6.1	6.0	5.8	5.7	5.5	5.4	5.3		26
28							5.8	5.7	5.6	5.4	5.3	5.1	5.0	4.8	4.7	4.6		28
30								5.1	5.0	4.8	4.7	4.5	4.4	4.2	4.1	4.0		30
32									4.5	4.3	4.2	4.0	3.9	3.7	3.6	3.4		32
34									33m /4.3	3.9	3.8	3.6	3.5	3.2	3.1	2.9		34
36										3.6	3.4	3.2	3.0	2.7	2.6	2.4		36
38											3.0	2.8	2.6	2.3	2.2	2.0		38
40												2.5	2.3	2.0	1.9	1.6		40

Note: Ratings inside shown in are determined by the strength of the boom or other structural components.

Boom Component Chart

Boom length m (ft)	Boom arrangement
12.19 (40)	Base-Tip
15.24 (50)	Base-A-Tip
18.29 (60)	Base-B-Tip, Base-A-A-Tip
21.34 (70)	Base-A-B-Tip, Base-C-Tip
24.38 (80)	Base-A-C-Tip, Base-B-B-Tip, Base-A-A-B-Tip,
27.43 (90)	Base-B-C-Tip, Base-A-B-B-Tip, Base-A-A-C-Tip
30.48 (100)	Base-A-B-C-Tip, Base-B-B-B-Tip, Base-A-A-B-B-Tip,
33.53 (110)	Base-B-B-C-Tip, Base-A-C-C-Tip, Base-B-B-A-B-Tip, Base-A-A-B-C-Tip

Boom length m (ft)	Boom arrangement
36.58 (120)	Base-B-C-C-Tip, Base-A-B-B-C-Tip
39.62 (130)	Base-A-B-C-C-Tip, Base-C-C-C-Tip
42.67 (140)	Base-B-B-C-C-Tip, Base-A-A-B-C-C-Tip, Base-A-C-C-C-Tip
45.72 (150)	Base-B-C-C-C-Tip, Base-A-B-B-C-C-Tip
48.77 (160)	Base-A-B-C-C-C-Tip
51.82 (170)	Base-A-B-C-A-C-C-Tip, Base-C-C-B-B-C-Tip
54.86 (180)	Base-A-B-C-B-C-C-Tip
57.91 (190)	Base-A-A-B-B-C-C-C-Tip

Base = 7.62m(20'), Tip = 10.67m(20')
 Inserts: A = 3.05 m (10'), B = 6.10 m (20'), C = 9.14m (30')

Clamshell ratings in metric tons for 360° working area

Crawler fully extended

Working radius m	Boom length m (ft)	12.2 (40)	15.2 (50)	18.3 (60)	21.3 (70)
6.0		12.5			
7.0		12.5	12.5		
8.0		12.5	12.5	12.5	
9.0		12.5	12.5	12.5	12.5
10.0		12.5	12.5	12.5	12.5
12.0		12.5	12.5	12.5	12.5
14.0			12.5	12.5	12.5
16.0				11.5	11.3
18.0					9.7

Note:

- Working radius is the horizontal distance between the center of rotation and the bucket's center of gravity.
- Total weight of bucket and materials must not exceed rated load.
 $\text{Bucket capacity (m}^3\text{)} \times \text{specific gravity of material (ton/m}^3\text{)} + \text{bucket weight (ton)} \leq \text{rated load}$
- Rated load must not be exceeded, even when using bucket of different capacity for separate task.
- When 28 mm dia. wire rope is used, Bucket unit weight must not exceed 6.0 tons (when the 28 mm dia. wire rope is used). Bucket weight must also be decreased according to operating cycle and bucket lowering height.
- Rated loads are determined by degree of stability. During simultaneous operations of boom and swing, rapid acceleration or deceleration must be avoided. Particular care is required with long boom lengths.
- Maximum working depth is 10 meters below the water level. However, it is necessary to reduce the working depth according to the bucket weight and working cycle.

Working Range

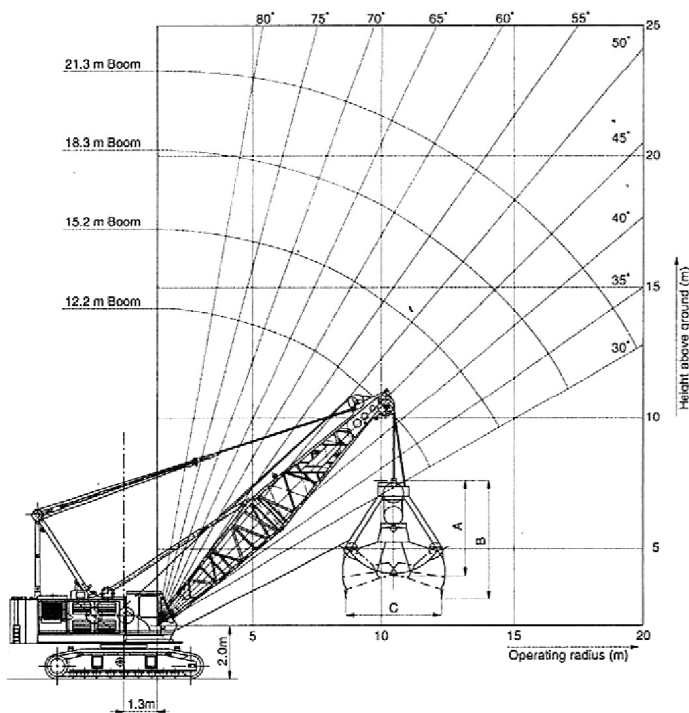

Clamshell Bucket

Bucket capacity (m ³)	Approximate bucket weight (ton)	Bucket dimensions (m)			Application
		A	B	C	
0.8	4.5	3.7	4.5	3.2	Digging
1.0	5.0	3.4	4.2	3.6	Digging
1.2	6.0	3.6	4.6	3.7	Digging

KOBELCO

HEAVY DUTY BASE MACHINE FOR FOUNDATION WORK BM800

Address inquiries to:

NOTE: Due to our policy of continual product improvement, all designs and specifications are subject to change without advance notice.



KOBE STEEL, LTD.

ENGINEERING & MACHINERY DIVISION
Construction Machinery & Compressor Group

KOBELCO Bldg., 3-2, Toyo 2-chome, Koto-ku, TOKYO, 135 Japan
Tel: (03)5634-5312/ Fax: (03) 5634-5533

This catalog is printed on recycled paper.
950203TF Printed in Japan