



# GTC-600

## 60t Telescopic Boom Crawler Crane

SPECIFICATION SHEET NO. TMC-DI-734-15 03/18

### GENERAL DATA

<b>CRANE CAPACITY</b>	60t at 3.0m
<b>BOOM</b>	4-section, 11.5 m – 36.0 m
<b>DIMENSION</b>	
Overall Length	14.03 m
Overall Width (tracks extended)	4.92 m
Overall Width (tracks retracted)	3.27 m
Overall Height (working)	3.89 m
<b>MASS</b>	
Gross Vehicle Mass (Standard Equipment Package)	63,387 kg
Maximum Counterweight	Upper = 13,608 kg Carbody = 6,000 kg
<b>PERFORMANCE</b>	
Travel Speed	1.3 km/hr/ 3.8 km/hr
Gradeability	78%

### CRANE SPECIFICATION

MODEL	CAPACITY
GTC-600	60t at 3.0m

#### BOOM

4-section full power telescoping boom with 2 extension modes. System consists of two double acting cylinders with load holding valves and extension and retraction cables.

- Retracted Length: 11.5m
- Extended Length: 36.0 m
- Elevating Angles: -1.5° to 80.0°
- Max Lifting Height: 38.2m
- Boom Head: Five, 495 mm diameter cast nylon main sheaves on heavy-duty roller bearings. Two, 445mm diameter cast nylon lead in sheaves on heavy-duty roller bearings). Designed for quick reeving of head and load block.
- Extension Time: 125 s
- Elevating Time: 89 s

#### AUXILIARY BOOM HEAD

Quick reeve, single 445 mm diameter high-strength, steel sheave mounted on a heavy-duty roller bearing. Allows single part reeving.

### COUNTERWEIGHT

4 piece counterweight design. Two upper counterweight configurations

- "A" Configuration = 6,804 kg
- "B" Configuration = 13,608 kg
- Two carbody counterweights, 3,000kg each

### WINCHES

Planetary geared two-speed winch includes a hydraulic motor, multi-disc internal brake and counterbalance valve. Drum rotation indicator is included (complete winch performance specs on Page 3)

- Main Winch
  - o Rope Diameter and Length: 19mm x 198m
  - o Single line pull: 88.2 kN(first layer)
  - o Single line speed: 112.2 m/min (4th layer)
- Auxiliary Winch
  - o Rope Diameter and Length: 19mm x 125m
  - o Single line pull: 88.2 kN (first layer)
  - o Single line speed: 112.2 m/min (4th layer)

### TRAVEL

Each side frame contains a pilot controlled, two-speed track drive with hydraulic axial piston motor and parking brake. Travel system provides skid steering and counter rotation.

- Travel speed - Low: 1.3 km/hr High: 3.8 km/hr
- Gradeability (unladen): 78%
- Unladen Ground Pressure: 0.67 kg/cm<sup>2</sup>

### SWING

Gear motor driving a planetary gear reducer with a shaft mounted pinion, external gear shear ball slew bearing bolted to the superstructure and the carbody allows the superstructure to rotate 360°

- Swing Speed: 0 - 2.2 rpm
- Swing Parking Brake: Spring applied failsafe brake with hydraulic release that is controlled from the operators cab
- Swing Service Brake: Hydraulically applied, controlled through foot actuated pedal
- House Lock System
  - o 4-position house lock (boom over front, rear or either side).
  - Actuated from the operator's cab.

### LOAD MOMENT INDICATOR

TADANO AML-C Rated Capacity Limiter and Anti-Two Block system

- OPTI-WIDTH™ - OPTIMAL lifting performance at any track WIDTH
- Control function shutdown. Audible and visual warnings
- LCD screen provides a continuous display of working boom length, boom angle, working load radius, tip height, swing position, parts-of-line (operator set), machine track configuration, relative load moment, maximum permissible load and actual load.
- Anti-two block weight allows quick reeving of hook block
- Operator configurable working range limits with automatic soft stop.

**FRAME**

The frame is an all-steel, welded structure, precision machined to accept attachment of the boom and swing components.

**OPERATORS CAB**

Fully-enclosed, air conditioned all-steel modular cab with lockable sliding door, acoustical lining, anti-slip floor and tinted safety glass.

- Cab tilts 20°.
- Rear view, winch view and right side view video cameras
- Three remote control work lights.
- Vent window in the rear of the cab.
- Grab bars and steps are located for easy access to the cab.
- Defroster, heater, circulating fan
- 2-speed windshield wiper, top glass wiper
- Six-way adjustable fabric seat with headrest, seat belt
- Dome light
- Dry-chemical fire extinguisher
- Four-way electronic armrest mounted joysticks control swing, main winch, auxiliary winch, boom hoist and boom extend. Foot pedals control the travel and swing service brake functions. Swing brake pedal is hydraulic.
- Selectable modes for Fine Control and Travel. Travel function can be operated by foot pedals or joystick.
- Seat termination switch immediately disable all hydraulic functions as the operator rises from the seat. Functions can also be disabled by switch on console.
- Dash instrumentation: tachometer, hour meter, fuel gauge, and DEF level gauge. Indicators are provided for crane level, swing position, load moment, drum rotation, air filter restriction, engine oil temperature and pressure, hydraulic oil temperature and level, and hydraulic and air filter restriction, and low voltage.

**ENGINE**

- Make/ Model: Cummins QSB6.7
- Type: 6 Cylinder, Water cooled, 4 Cycle
- Aspiration: Turbocharged and Aftercooled
- Max.Output: 231 kW @ 2200 RPM
- Max Torque: 1,044 Nm @ 1500 RPM
- Piston Disp: 6.7 L
- Emission Cert: U.S. EPA Tier 4f, Euromot Stage IV
- Alternator: 70 amp

**ELECTRICAL SYSTEM**

24 VDC

**FUEL SYSTEM**

- Capacity: 321 liter
- Filtration: Inline fuel/water separator and engine mounted fuel filter

**SIDE FRAMES**

Two welded steel side frames are paired with a track group. The side frames extend and retract hydraulically and are controlled from the cab.

- Track Rollers: Two top and thirteen bottom sealed rollers on each track frame Idler: Oil filled, self lubricating with nitrogen type tensioner
- Track Shoes: 900 mm, 3-bar semi grouser

**HYDRAULIC SYSTEM**

- Hydraulic Pumps: Two high pressure, variable axial piston pumps with load sense and power limiting control for crane functions. One axial piston pump for swing function. One gear pump for cooling loop.
- Directional Valves: Multiple pressure and flow compensated valves with integrated relief valves controlled by electrical signals.
- Pump output: 582 l/min @ 2200 RPM engine speed. 345 bar maximum pressure
- Reservoir: 861 liter capacity, spin-on filler/ breather, sight gauge, cleanout, and sump drain.
- Filtration: Three 5 micron, full flow tank mounted return filters with electrical clogging indicator. 3 micron pilot oil in-line pressure filter
- Diagnostic Ports: Provided for system, load sense, and pilot pressure

**BI-FOLD JIB**

## o Main jib

- Total Length: 10.1m
- Max. Lifting Height: 48.1 m
- Offset Angles: 3.5°, 25° & 45°

## o Fly jib

- Total Length: 17.7m
- Max. Lifting Height: 55.5 m
- Offset Angles: 3.5°, 25° & 45°

**OPTIONAL EQUIPMENT**

- Heavy lift jib
  - Total Length: 2.5 m
  - Max. Lifting Height: 40.5 m
  - Offset Angles: 3.5° & 30°
- Hook blocks
  - o 60t quick reeve hook block – Five, 495mm steel sheaves, swivel hook and safety latch
  - o 50t quick reeve hook block – three, 495mm steel sheaves, swivel hook and safety latch
  - o 20t quick reeve hook block – one, 495mm steel sheave, swivel hook and safety latch
- Overhaul ball – 8t with swivel hook & safety latch
- 360 degree house lock. Actuate d from the operator's cab.
- Track Shoes: 800mm and 900mm steel flat shoes, and 800 mm 3-bar semi grousers
- Auger: Hydraulic auger boom package includes auger motor, hoses, fasteners, and stowage bracket assembly mounted to the 2nd stage section of boom for variable radius drilling.
- Tool Circuit: Provides 23 l/min and 45 l/min at 176 bar through a 15.2m twin hose reel with quick disconnect fittings to operate open center tools.
- High Flow Tool Circuit: Provides 170 l/min at 330 bar
- Controlled Free Fall Hoists: Winches are available in controlled free fall configurations.
- Cold Weather Packages: Cold weather options are available for operation to -40°C (Consult factory for application support)
- Work Platform: Model WP750 – 0.9m x 1.8m, all steel, welded, two person platform with maximum capacity of 340 kg (available in approved markets only).
- Radio control package (available in approved markets only).
- Anemometer: boom mounted wireless anemometer with cab display.
- Central lubrication system.

<b>MAIN WINCH AND AUXILIARY WINCH PERFORMANCE</b>						
Wire Rope: 19 mm diameter rotation resistant. Line pulls are not based on wire rope strength.						
<b>Rope Layer</b>	<b>Maximum Line Pull (kN)</b>	<b>High Line Speed (m/min)</b>	<b>Normal Line Speed (m/min)</b>	<b>Pitch Diameter (mm)</b>	<b>Layer (m)</b>	<b>Total (m)</b>
1	88.2	88.5	52.6	381	34.2	34.2
2	79.9	96.4	57.3	421.6	37.3	71.5
3	73	104.3	62.1	462.3	40.3	111.8
4	67.2	112.2	66.8	500.1	43.4	155.2
5	62.3	120.9	71.5	541	46.4	201.5
6	58	128.1	76.2	581.7	49.5	251

<b>MACHINE WEIGHTS</b>	<b>KG</b>
<b>Standard Crane</b> with 4 section - 36 m boom, full counterweight, 2 winches with wire rope, bi-fold jib, auxiliary nose sheave and 900 mm 3-bar semi grouser track shoes	63,387
<b>Standard Crane</b> with 4 section - 36 m boom, 2 winches with wire rope, bi-fold jib, auxiliary nose sheave and 900 mm 3-bar semi grouser track shoes (counterweight removed)	43,779
<b>OPTIONAL EQUIPMENT</b>	<b>KG</b>
Heavy Lift Jib (2.5 m)	441
Jib Base (10.1 m)	919
Jib Tip (7.5 m)	339
Auxiliary Nose Sheave	48
60t hook block - five sheave	543
50t hook block - three sheave	633
20t hook block - one sheave	296
8t Overhaul Ball	133

## DIMENSIONS

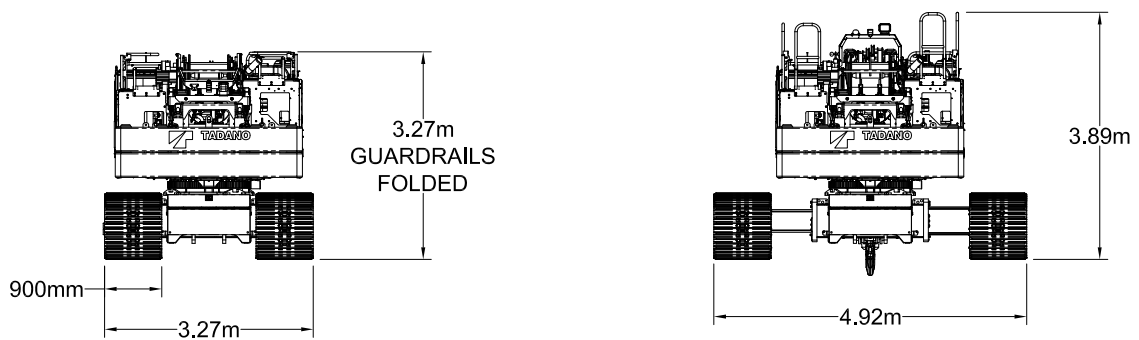
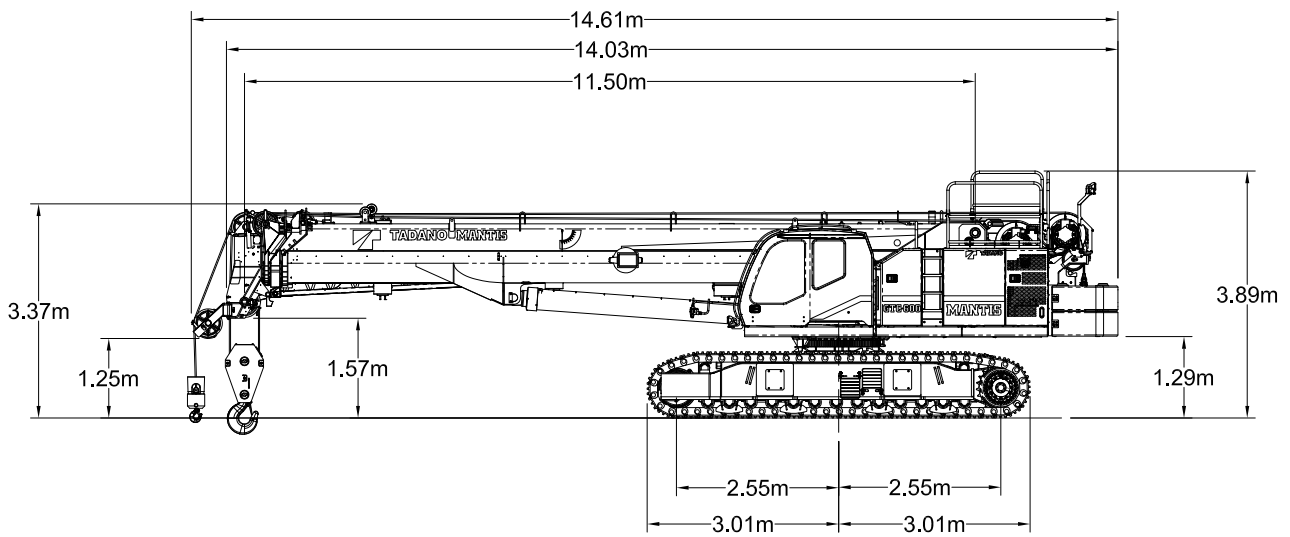
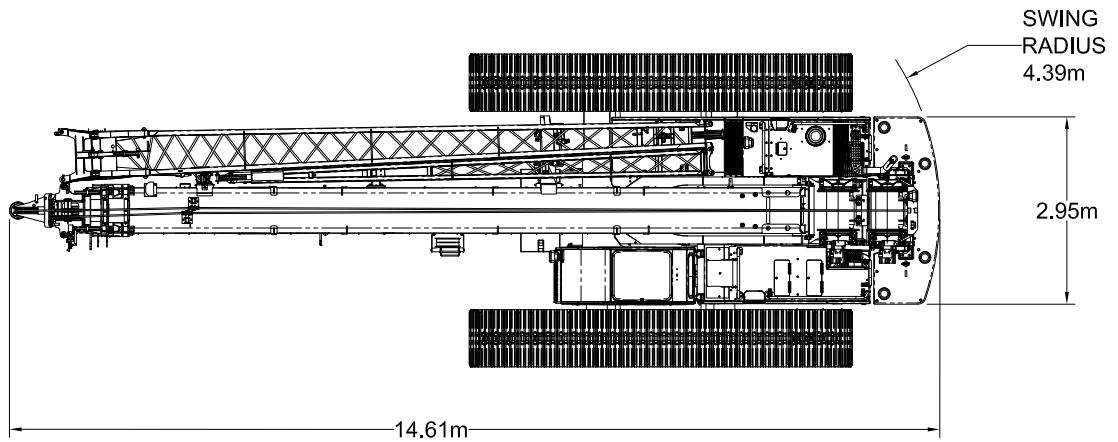

**TRANSPORT DIMENSIONS**

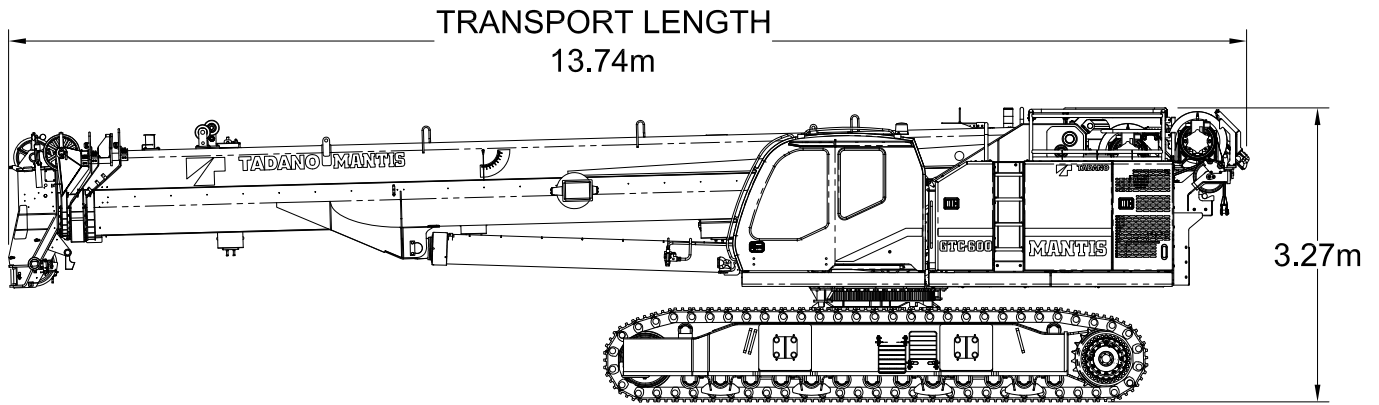

**TRANSPORT PLAN**

Item	Weight	Dims	Trailer	
	Kg	(L x W x H)	1	2
Crane (with 2 winches, Boom, wire rope, aux nose sheave)	41,907	13.74 m X 3.28 m X 3.28 m	X	
Counterweight A	6,804	2.95 m X 1.12 m X 1.04 m		X
Counterweight B - 1 piece	6,804	2.95 m X 0.46 m X 1.04 m		X
Counterweight - Carbody - 1 piece	3,000	1.30 m X 0.97 m X 0.74 m		X
Counterweight - Carbody - 1 piece	3,000	1.30 m X 1.45 m X 0.76 m		X
Jib base section	919	10.57 m X 1.47 m X 0.91 m	X	
Jib point	339	7.85 m X 0.74 m X 0.74 m	X	
Hook Block - 60 metric ton	543	1.57 m X 0.61 m X 0.46 m	X	
Headache Ball - 8 ton	133	0.74 m X 0.28 m X 0.28 m	X	
Miscellaneous Items (Crate)	23	1.22 m X 0.91 m X 0.91 m	X	
<b>Total Net Weight on Trailer (KGs)</b>			<b>43,864</b>	<b>19,608</b>

**TRANSPORT DIMENSIONS**

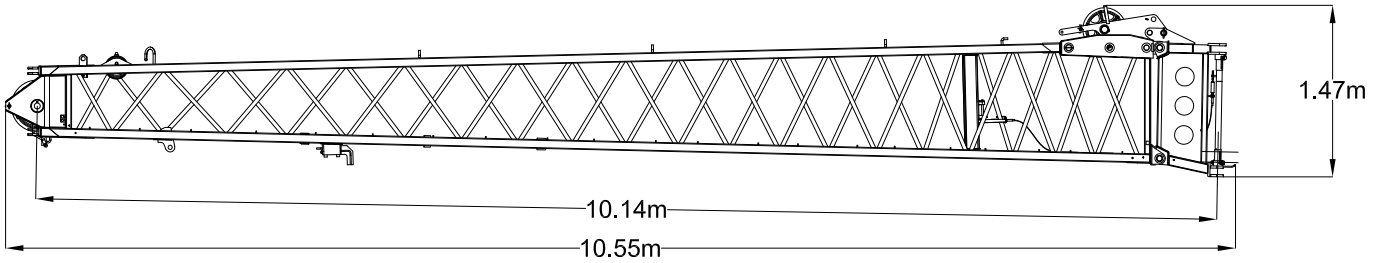

**10.1m EXTENSION**  
WEIGHT: 919 kg

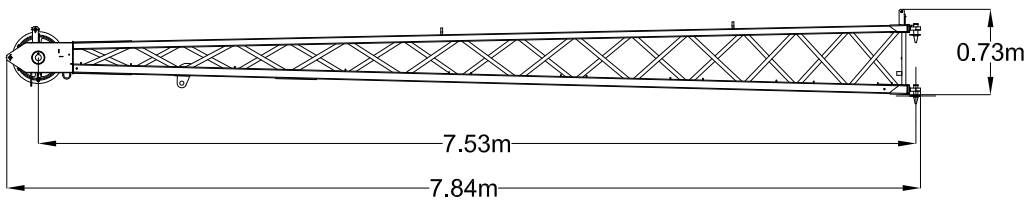

**7.5m JIB POINT**  
WEIGHT: 339 kg

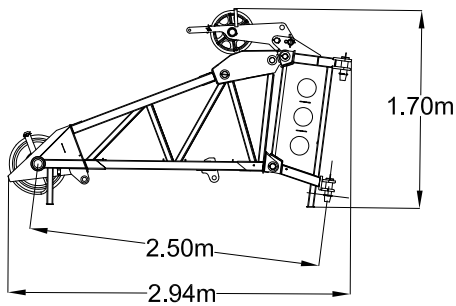

**2.5m HEAVY LIFT JIB**  
WEIGHT: 441 kg

**TRANSPORT DIMENSIONS**

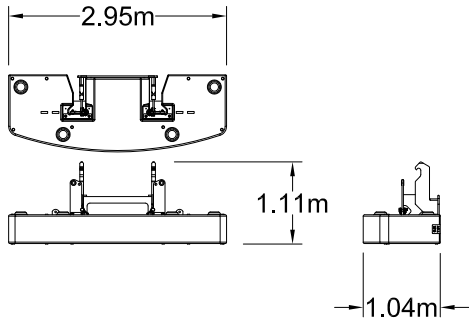

**CONFIGURATION "A"**  
WEIGHT: 6804 kg

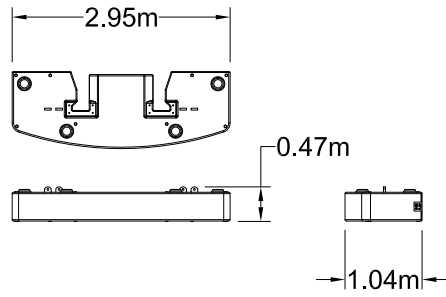

**CWT "B" SECTION**  
WEIGHT: 6804 kg

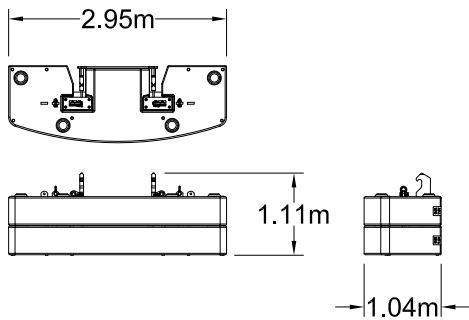

**CONFIGURATION "B"**  
WEIGHT: 13607 kg

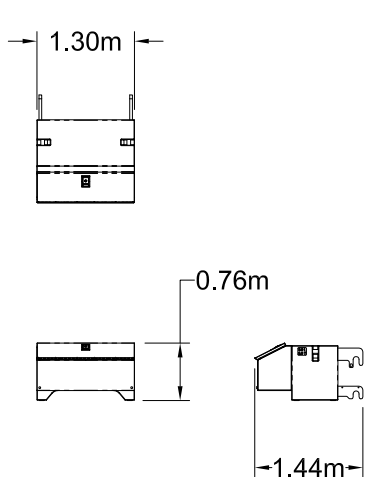

**REAR CARBODY CWT**  
WEIGHT: 3000 kg

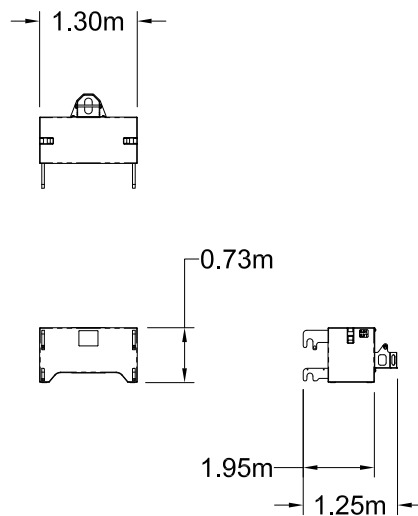

**FRONT CARBODY CWT**  
WEIGHT: 3000 kg

**WORKING RANGE DIAGRAM - HEAVY LIFT JIB**

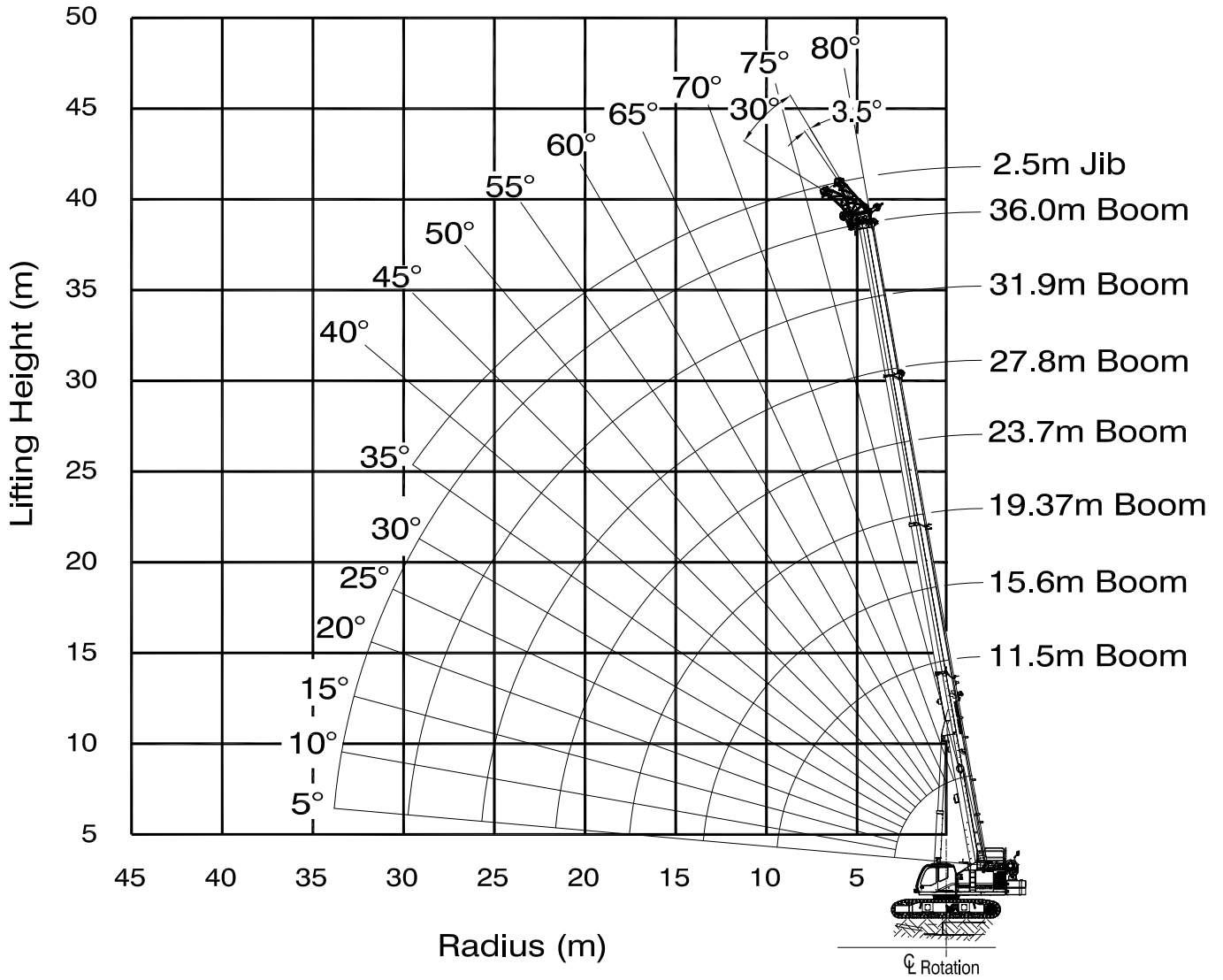



**WORKING RANGE DIAGRAM**

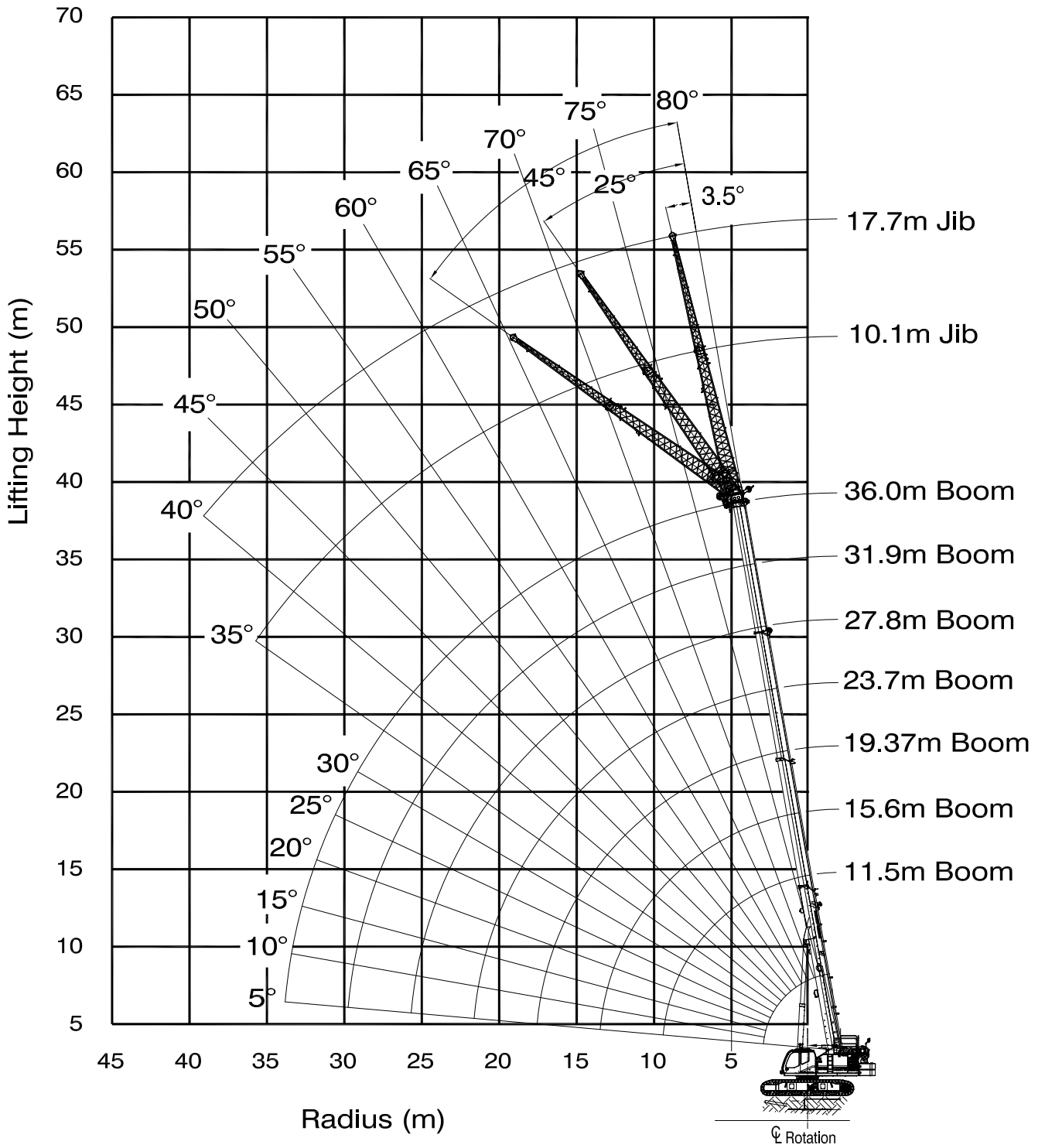

**LOAD CHARTS****LOADS IN lb x 1000****ALL LOADS IN kg x 1000**

<b>MAIN BOOM with TRACKS FULLY EXTENDED - 360°</b>								
<b>UP to 1.5° SLOPE - NO TRAVEL</b>								
<b>13.6 t MAIN COUNTERWEIGHT AND 6.0 t CARBODY COUNTERWEIGHT</b>								
<b>RADIUS</b> <b>(m)</b>	<b>MAIN BOOM LENGTH (m)</b>							<b>RADIUS</b> <b>(m)</b>
	<b>11.5</b>	<b>15.6</b>	<b>19.7</b>	<b>23.8</b>	<b>27.8</b>	<b>31.9</b>	<b>36.0</b>	
<b>3</b>	<b>60.0</b>	<b>52.4</b>	<b>45.8</b>					<b>3</b>
<b>4</b>	<b>50.4</b>	<b>49.8</b>	<b>34.9</b>	<b>16.9</b>	<b>16.5</b>			<b>4</b>
<b>5</b>	<b>39.9</b>	<b>38.2</b>	<b>34.1</b>	<b>16.9</b>	<b>16.4</b>	<b>15.7</b>		<b>5</b>
<b>6</b>	<b>32.7</b>	<b>30.7</b>	<b>27.7</b>	<b>16.9</b>	<b>16.4</b>	<b>15.7</b>	<b>13.5</b>	<b>6</b>
<b>7</b>	<b>27.0</b>	<b>25.5</b>	<b>23.1</b>	<b>16.9</b>	<b>16.4</b>	<b>15.6</b>	<b>13.5</b>	<b>7</b>
<b>8</b>	<b>22.1</b>	<b>21.0</b>	<b>19.7</b>	<b>16.9</b>	<b>16.4</b>	<b>15.5</b>	<b>12.9</b>	<b>8</b>
<b>9</b>	<b>18.7</b>	<b>17.6</b>	<b>16.9</b>	<b>16.6</b>	<b>16.1</b>	<b>15.4</b>	<b>12.0</b>	<b>9</b>
<b>10</b>		<b>16.2</b>	<b>16.2</b>	<b>14.6</b>	<b>14.2</b>	<b>13.8</b>	<b>11.2</b>	<b>10</b>
<b>12</b>		<b>12.5</b>	<b>12.5</b>	<b>12.3</b>	<b>11.3</b>	<b>11.2</b>	<b>9.8</b>	<b>12</b>
<b>14</b>			<b>10.0</b>	<b>10.1</b>	<b>9.0</b>	<b>9.1</b>	<b>8.7</b>	<b>14</b>
<b>16</b>			<b>8.3</b>	<b>8.3</b>	<b>7.2</b>	<b>7.3</b>	<b>7.5</b>	<b>16</b>
<b>18</b>				<b>7.0</b>	<b>5.9</b>	<b>6.5</b>	<b>6.2</b>	<b>18</b>
<b>20</b>				<b>6.0</b>	<b>5.2</b>	<b>5.6</b>	<b>5.2</b>	<b>20</b>
<b>22</b>					<b>4.7</b>	<b>4.8</b>	<b>4.4</b>	<b>22</b>
<b>24</b>					<b>4.3</b>	<b>4.1</b>	<b>3.7</b>	<b>24</b>
<b>26</b>						<b>3.5</b>	<b>3.2</b>	<b>26</b>
<b>28</b>						<b>3.0</b>	<b>2.7</b>	<b>28</b>
<b>30</b>							<b>2.3</b>	<b>30</b>
<b>32</b>							<b>2.0</b>	<b>32</b>
<b>PARTS OF LINE</b>	<b>10</b>	<b>8</b>	<b>8</b>	<b>4</b>	<b>4</b>	<b>4</b>	<b>2</b>	<b>PARTS OF LINE</b>

Load chart data is for reference, load charts supplied in the crane cab shall be used for lift planning.

**LOAD CHARTS**

**LOADS IN lb x 1000**

**ALL LOADS IN kg x 1000**

<b>MAIN BOOM with TRACKS FULLY EXTENDED - 360°</b>								
<b>UP to 4° SLOPE - NO TRAVEL</b>								
<b>13.6 t MAIN COUNTERWEIGHT AND 6.0 t CARBODY COUNTERWEIGHT</b>								
RADIUS (m)	MAIN BOOM LENGTH (m)							RADIUS (m)
	11.5	15.6	19.7	23.8	27.8	31.9	36.0	
3	59.1	43.5	34.9					3
4	47.6	39.3	33.4	16.9	16.5			4
5	37.3	31.4	27.2	16.9	16.4	14.3		5
6	29.7	26.0	22.8	16.9	16.4	14.3	11.5	6
7	24.1	21.8	19.4	16.9	16.4	14.3	11.5	7
8	20.2	18.2	16.8	15.9	15.1	14.3	11.4	8
9	17.5	16.7	16.2	14.1	13.4	12.7	10.7	9
10		14.6	14.2	13.1	12.0	11.5	10.0	10
12		11.6	11.2	10.9	9.6	9.4	8.9	12
14			9.2	9.0	7.7	7.6	7.7	14
16			7.7	7.5	6.3	6.7	6.3	16
18				6.4	5.5	5.8	5.3	18
20				5.6	5.0	4.9	4.5	20
22					4.6	4.2	3.8	22
24					4.2	3.7	3.3	24
26						3.2	2.8	26
28						2.8	2.4	28
30							2.0	30
32							1.8	32
PARTS OF LINE	10	4	4	4	2	2	2	PARTS OF LINE

Load chart data is for reference, load charts supplied in the crane cab shall be used for lift planning.

**LOAD CHARTS****LOADS IN lb x 1000****ALL LOADS IN kg x 1000**

<b>MAIN BOOM with TRACKS RETRACTED - OVER FRONT/REAR UP to 1.5° SLOPE - NO TRAVEL</b>								
<b>13.6 t MAIN COUNTERWEIGHT AND 6.0 t CARBODY COUNTERWEIGHT</b>								
<b>RADIUS (m)</b>	<b>MAIN BOOM LENGTH (m)</b>							<b>RADIUS (m)</b>
	<b>11.5</b>	<b>15.6</b>	<b>19.7</b>	<b>23.8</b>	<b>27.8</b>	<b>31.9</b>	<b>36.0</b>	
<b>3</b>	<b>60.0</b>	<b>52.4</b>	<b>45.8</b>					<b>3</b>
<b>4</b>	<b>50.4</b>	<b>50.0</b>	<b>34.9</b>	<b>16.9</b>	<b>16.5</b>			<b>4</b>
<b>5</b>	<b>39.9</b>	<b>39.5</b>	<b>34.2</b>	<b>16.9</b>	<b>16.4</b>	<b>15.7</b>		<b>5</b>
<b>6</b>	<b>32.7</b>	<b>32.4</b>	<b>30.9</b>	<b>16.9</b>	<b>16.4</b>	<b>15.7</b>	<b>13.5</b>	<b>6</b>
<b>7</b>	<b>27.6</b>	<b>27.2</b>	<b>26.9</b>	<b>16.9</b>	<b>16.4</b>	<b>15.6</b>	<b>13.5</b>	<b>7</b>
<b>8</b>	<b>23.7</b>	<b>23.3</b>	<b>23.0</b>	<b>16.9</b>	<b>16.4</b>	<b>15.5</b>	<b>12.9</b>	<b>8</b>
<b>9</b>	<b>20.6</b>	<b>20.2</b>	<b>19.9</b>	<b>16.9</b>	<b>16.4</b>	<b>15.4</b>	<b>12.0</b>	<b>9</b>
<b>10</b>		<b>17.8</b>	<b>17.5</b>	<b>16.9</b>	<b>15.7</b>	<b>14.3</b>	<b>11.2</b>	<b>10</b>
<b>12</b>		<b>15.1</b>	<b>15.1</b>	<b>13.7</b>	<b>13.5</b>	<b>12.3</b>	<b>9.8</b>	<b>12</b>
<b>14</b>			<b>12.1</b>	<b>11.0</b>	<b>10.9</b>	<b>10.7</b>	<b>8.7</b>	<b>14</b>
<b>16</b>			<b>10.0</b>	<b>10.0</b>	<b>8.9</b>	<b>9.0</b>	<b>7.8</b>	<b>16</b>
<b>18</b>				<b>8.4</b>	<b>7.3</b>	<b>7.5</b>	<b>7.1</b>	<b>18</b>
<b>20</b>				<b>7.2</b>	<b>6.1</b>	<b>6.3</b>	<b>6.4</b>	<b>20</b>
<b>22</b>					<b>5.2</b>	<b>5.3</b>	<b>5.5</b>	<b>22</b>
<b>24</b>					<b>4.4</b>	<b>4.9</b>	<b>4.7</b>	<b>24</b>
<b>26</b>						<b>4.4</b>	<b>4.1</b>	<b>26</b>
<b>28</b>						<b>3.9</b>	<b>3.5</b>	<b>28</b>
<b>30</b>							<b>3.1</b>	<b>30</b>
<b>32</b>							<b>2.7</b>	<b>32</b>
<b>PARTS OF LINE</b>	<b>10</b>	<b>8</b>	<b>8</b>	<b>4</b>	<b>4</b>	<b>4</b>	<b>2</b>	<b>PARTS OF LINE</b>

Load chart data is for reference, load charts supplied in the crane cab shall be used for lift planning.

**LOAD CHARTS**

**LOADS IN lb x 1000**

**ALL LOADS IN kg x 1000**

<b>MAIN BOOM with TRACKS FULLY RETRACTED - OVER SIDE</b> <b>UP to 1.5° SLOPE - NO TRAVEL</b> <b>13.6 t MAIN COUNTERWEIGHT AND 6.0 t CARBODY COUNTERWEIGHT</b>								
RADIUS (m)	MAIN BOOM LENGTH (m)							RADIUS (m)
	11.5	15.6	19.7	23.8	27.8	31.9	36.0	
3	*	*	*					3
4	*	*	*	*	*			4
5	*	*	*	*	*	*		5
6	20.4	*	*	*	*	*	*	6
7	16.5	15.6	*	*	*	*	*	7
8	13.6	14.0	13.8	*	*	*	*	8
9	11.5	11.8	11.9	11.7	*	10.3	9.5	9
10		10.2	10.3	10.3	9.7	9.2	8.4	10
12		7.8	7.9	8.0	8.1	7.4	6.7	12
14			6.3	6.4	6.5	6.0	5.5	14
16			5.1	5.2	5.3	4.9	4.5	16
18				4.3	4.4	4.0	3.6	18
20				3.6	3.6	3.2	2.9	20
22					3.1	2.7	2.3	22
24					2.6	2.2	1.9	24
26						1.8	1.5	26
28						1.5	1.1	28
30							0.8	30
32							0.6	32
PARTS OF LINE	10	8	8	4	4	4	2	PARTS OF LINE

Load chart data is for reference, load charts supplied in the crane cab shall be used for lift planning.

**LOAD CHARTS**

**LOADS IN lb x 1000**

**ALL LOADS IN kg x 1000**

<b>MAIN BOOM with TRACKS FULLY EXTENDED - 360°</b> <b>UP to 1.5° SLOPE - NO TRAVEL</b> <b>0 t MAIN COUNTERWEIGHT AND 6.0 t CARBODY COUNTERWEIGHT</b>								
RADIUS (m)	MAIN BOOM LENGTH (m)							RADIUS (m)
	11.5	15.6	19.7	23.8	27.8	31.9	36.0	
3	48.8	39.4	32.9					3
4	32.6	27.4	23.6	16.9	16.5			4
5	24.0	20.6	18.0	16.9	16.0	15.0		5
6	18.7	16.9	16.4	15.4	13.0	13.1	11.8	6
7	14.4	14.4	13.7	12.9	11.3	11.1	10.0	7
8	11.5	11.9	11.6	11.0	10.6	9.5	8.6	8
9	9.5	9.8	9.9	9.6	9.2	8.2	7.4	9
10		8.3	8.4	8.3	8.1	7.2	6.5	10
12		6.1	6.2	6.3	6.3	5.6	5.0	12
14			4.7	4.8	5.0	4.4	3.9	14
16			3.7	3.8	3.9	3.5	3.0	16
18				3.0	3.1	2.7	2.4	18
20				2.4	2.5	2.1	1.8	20
22					2.0	1.6	1.3	22
24					1.6	1.2	0.9	24
26						0.8	*	26
28						0.6	*	28
30							*	30
32							*	32
PARTS OF LINE	10	8	8	4	4	4	2	PARTS OF LINE

Load chart data is for reference, load charts supplied in the crane cab shall be used for lift planning.

**LOAD CHARTS**

**LOADS IN lb x 1000**

ALL LOADS IN kg x 1000

<b>AUX NOSE SHEAVE with TRACKS FULLY EXTENDED - 360°</b> <b>UP to 1.5° SLOPE - NO TRAVEL</b> <b>13.6 t MAIN COUNTERWEIGHT AND 6.0 t CARBODY COUNTERWEIGHT</b>								
RADIUS (m)	MAIN BOOM LENGTH (m)							RADIUS (m)
	11.5	15.6	19.7	23.8	27.8	31.9	36.0	
3	6.6	6.6	6.6					3
4	6.6	6.6	6.6	6.6				4
5	6.6	6.6	6.6	6.6	6.6			5
6	6.6	6.6	6.6	6.6	6.6	6.6	6.6	6
7	6.6	6.6	6.6	6.6	6.6	6.6	6.6	7
8	6.6	6.6	6.6	6.6	6.6	6.6	6.6	8
9	6.6	6.6	6.6	6.6	6.6	6.6	6.6	9
10	6.6	6.6	6.6	6.6	6.6	6.6	6.6	10
12		6.6	6.6	6.6	6.6	6.6	6.6	12
14		6.6	6.6	6.6	6.6	6.6	6.6	14
16			6.6	6.6	6.6	6.6	6.6	16
18			6.6	6.6	6.1	6.3	6.4	18
20				6.1	5.1	5.3	5.4	20
22				5.3	4.3	4.9	4.5	22
24					3.9	4.2	3.9	24
26					3.6	3.6	3.3	26
28						3.1	2.8	28
30						2.7	2.4	30
32							2.0	32
34							1.7	34
PARTS OF LINE	1	1	1	1	1	1	1	PARTS OF LINE

Load chart data is for reference, load charts supplied in the crane cab shall be used for lift planning.

**LOAD CHARTS**

**LOADS IN lb x 1000**

ALL LOADS IN kg x 1000

2.5M JIB with TRACKS FULLY EXTENDED - 360°											
UP to 1.5° SLOPE - NO TRAVEL											
13.6 t MAIN COUNTERWEIGHT AND 6.0 t CARBODY COUNTERWEIGHT											
RADIUS (m)	MAIN BOOM LENGTH (m)										RADIUS (m)
	11.5		23.8		27.8		31.9		36.0		
	3.5°	30°	3.5°	30°	3.5°	30°	3.5°	30°	3.5°	30°	
3	20.4	15.9									3
4	19.1	15.3	15.1								4
5	18.1	14.9	12.5	15.0	12.5						5
6	17.3	14.5	12.4	12.2	11.0	12.0	12.9				6
7	16.6	14.3	12.3	12.1	10.7	10.4	11.7	11.3	12.1		7
8	16.0	14.1	12.2	12.0	10.1	9.9	10.7	10.4	11.1	10.7	8
9	15.6	14.1	12.1	11.9	9.2	9.0	9.9	9.6	10.3	9.9	9
10	15.4	14.1	12.1	11.9	8.5	8.3	9.1	8.9	9.6	9.2	10
12			11.0	10.7	7.2	7.1	7.9	7.7	8.4	8.1	12
14			9.8	9.6	6.3	6.2	6.9	6.8	7.4	7.2	14
16			8.1	8.2	5.5	5.5	6.1	6.0	6.6	6.5	16
18			6.8	6.8	4.9	4.9	5.5	5.4	5.9	5.8	18
20			5.7	5.8	4.4	4.3	4.9	4.9	4.9	5.0	20
22			4.9		3.9	3.9	4.4	4.4	4.1	4.2	22
24			4.2		3.5	3.5	3.8	3.8	3.4	3.5	24
26					3.2		3.2	3.2	2.9	2.9	26
28					3.0		2.7	2.7	2.4	2.4	28
30							2.3		2.0	2.0	30
32							2.0		1.6	1.6	32
34									1.3		34
36									1.1		36
PARTS OF LINE	4	4	2	2	2	2	2	2	2	2	PARTS OF LINE

Load chart data is for reference, load charts supplied in the crane cab shall be used for lift planning.



**LOAD CHARTS**

**LOADS IN lb x 1000**

ALL LOADS IN kg x 1000

10.1M JIB with TRACKS FULLY EXTENDED - 360°																
UP to 1.5° SLOPE - NO TRAVEL																
13.6 t MAIN COUNTERWEIGHT AND 6.0 t CARBODY COUNTERWEIGHT																
RADIUS (m)	MAIN BOOM LENGTH (m)															RADIUS (m)
	11.5			23.8			27.8			31.9			36.0			
	3.5°	25°	45°	3.5°	25°	45°	3.5°	25°	45°	3.5°	25°	45°	3.5°	25°	45°	
3	6.6															3
4	6.6															4
5	6.6															5
6	6.6			6.6												6
7	6.6	6.6		6.6			6.6			6.6						7
8	6.6	6.6		6.6			6.6			6.6			6.0			8
9	6.6	6.4	5.4	6.6	6.6		6.6			6.6			6.0			9
10	6.6	6.1	5.2	6.6	6.6		6.6	6.5		6.6			6.0			10
12	6.6	5.5	4.8	6.6	6.3	5.1	6.4	6.1		6.6	6.3		6.0	6.4		12
14	6.0	5.1	4.6	6.6	5.9	4.9	6.0	5.8	4.9	6.3	5.9	5.0	6.0	5.8		14
16	5.4	4.8	4.5	6.6	5.5	4.7	5.4	5.2	4.7	5.6	5.3	4.8	5.7	5.3	4.8	16
18	5.0	4.5	*	6.3	5.2	4.5	4.8	4.7	4.6	5.0	4.8	4.6	5.2	4.9	4.7	18
20				5.8	5.0	4.4	4.3	4.2	4.2	4.6	4.4	4.3	4.7	4.5	4.3	20
22				5.4	4.8	4.3	3.9	3.8	3.8	4.2	4.0	4.0	4.3	4.1	4.0	22
24				4.7	4.6	4.3	3.6	3.5	3.5	3.8	3.7	3.7	3.9	3.8	3.7	24
26				4.1	4.3	4.3	3.3	3.2	3.2	3.5	3.4	3.4	3.3	3.6	3.5	26
28				3.6	3.8	*	3.0	3.0	3.0	3.2	3.2	3.2	2.8	3.1	3.3	28
30				3.2	3.3		2.8	2.7	*	2.8	2.9	3.0	2.4	2.7	2.8	30
32				2.9			2.6	2.6		2.4	2.6	2.6	2.1	2.3	2.4	32
34							2.4	2.4		2.1	2.2	*	1.8	1.9	2.0	34
36							2.2			1.8	1.9		1.5	1.6	*	36
38										1.6	1.6		1.2	1.3		38
40										1.4			1.0	1.1		40
PARTS OF LINE	1	1	1	1	1	1	1	1	1	1	1	1	1	1	1	PARTS OF LINE

Load chart data is for reference, load charts supplied in the crane cab shall be used for lift planning.

**LOAD CHARTS**

**LOADS IN lb x 1000**

ALL LOADS IN kg x 1000

17.1M JIB with TRACKS FULLY EXTENDED - 360°																
UP to 1.5° SLOPE - NO TRAVEL																
13.6 t MAIN COUNTERWEIGHT AND 6.0 t CARBODY COUNTERWEIGHT																
RADIUS (m)	MAIN BOOM LENGTH (m)															RADIUS (m)
	11.5			23.8			27.8			31.9			36.0			
	3.5°	25°	45°	3.5°	25°	45°	3.5°	25°	45°	3.5°	25°	45°	3.5°	25°	45°	
5	4.5															5
6	4.5															6
7	4.5															7
8	4.5			3.7												8
9	4.5			3.7			3.5									9
10	4.5			3.7			3.5			3.3						10
12	4.0	3.6		3.7			3.5			3.3			3.2			12
14	3.6	3.3		3.7	3.6		3.5			3.3			3.2			14
16	3.2	3.1	2.6	3.7	3.4		3.5	3.4		3.3	3.3		3.2			16
18	3.0	2.8	2.5	3.6	3.2	2.6	3.5	3.2		3.3	3.3		3.2	3.2		18
20	2.7	2.6	2.3	3.3	3.0	2.5	3.4	3.1	2.5	3.3	3.1	2.5	3.2	3.1		20
22	2.5	2.4	2.2	3.1	2.8	2.4	3.2	2.9	2.4	3.3	3.0	2.4	3.2	3.0	2.4	22
24	2.3	2.2	2.1	2.9	2.6	2.3	3.0	2.7	2.3	3.1	2.8	2.3	3.2	2.9	2.3	24
26	2.2	2.1		2.8	2.5	2.2	2.9	2.6	2.2	3.0	2.7	2.2	3.1	2.7	2.3	26
28				2.6	2.4	2.1	2.6	2.5	2.1	2.8	2.5	2.2	2.9	2.6	2.2	28
30				2.5	2.3	2.1	2.4	2.3	2.1	2.6	2.4	2.1	2.6	2.5	2.1	30
32				2.4	2.2	2.0	2.2	2.2	2.0	2.4	2.3	2.0	2.3	2.4	2.1	32
34				2.3	2.1	2.0	2.1	2.1	2.0	2.2	2.2	2.0	2.0	2.3	2.0	34
36				2.2	2.0	*	1.9	1.9	1.9	2.0	2.0	2.0	1.7	2.0	2.0	36
38				2.1	2.0		1.8	1.8	*	1.7	1.9	1.9	1.4	1.7	1.9	38
40							1.6	1.7		1.5	1.7	1.8	1.2	1.4	1.6	40
45										1.0	1.1		0.7	0.9	*	45
50													0.4	0.4		50
PARTS OF LINE	1	1	1	1	1	1	1	1	1	1	1	1	1	1	1	PARTS OF LINE

Load chart data is for reference, load charts supplied in the crane cab shall be used for lift planning.

## WP750 WORK PLATFORM ON MAIN BOOM RANGE CHART FOR MODEL GTC-600

as originally manufactured and equipped by Tadano Mantis Corporation

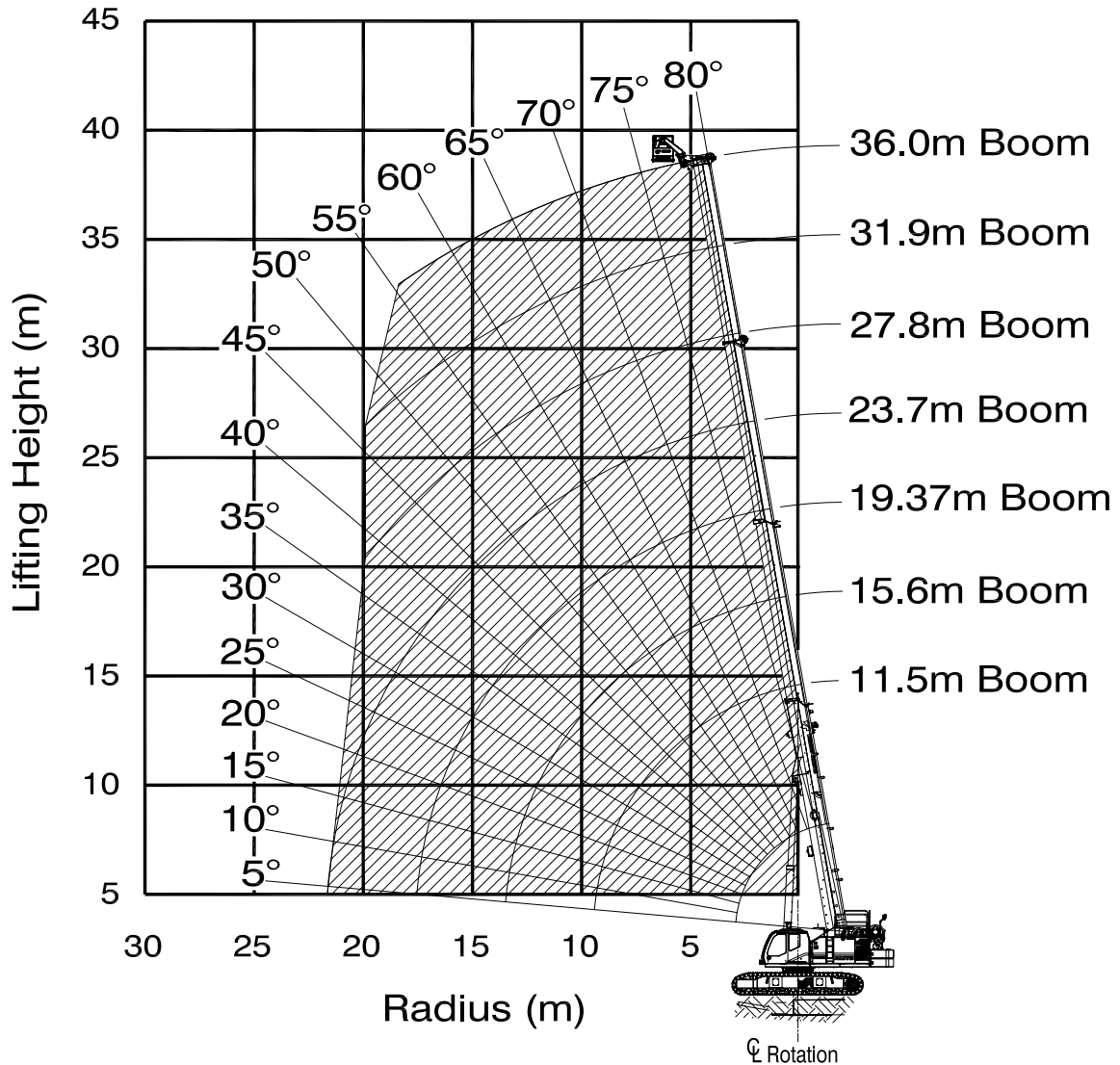

**Notes:**

1. It is permissible to leave the jibs stowed on the boom while operating with Work Platform mounted to the main boom.
2. The hook block(s) must be removed when using the Work Platform

**WARNING:** Lifting a load during Work Platform operation is **not** allowed.

**WARNING:** Travelling the crane with person(s) in the Work Platform is **not** allowed.

## WP750 WORK PLATFORM ON 10.1 M JIB RANGE CHART FOR MODEL GTC-600

as originally manufactured and equipped by Tadano Mantis Corporation

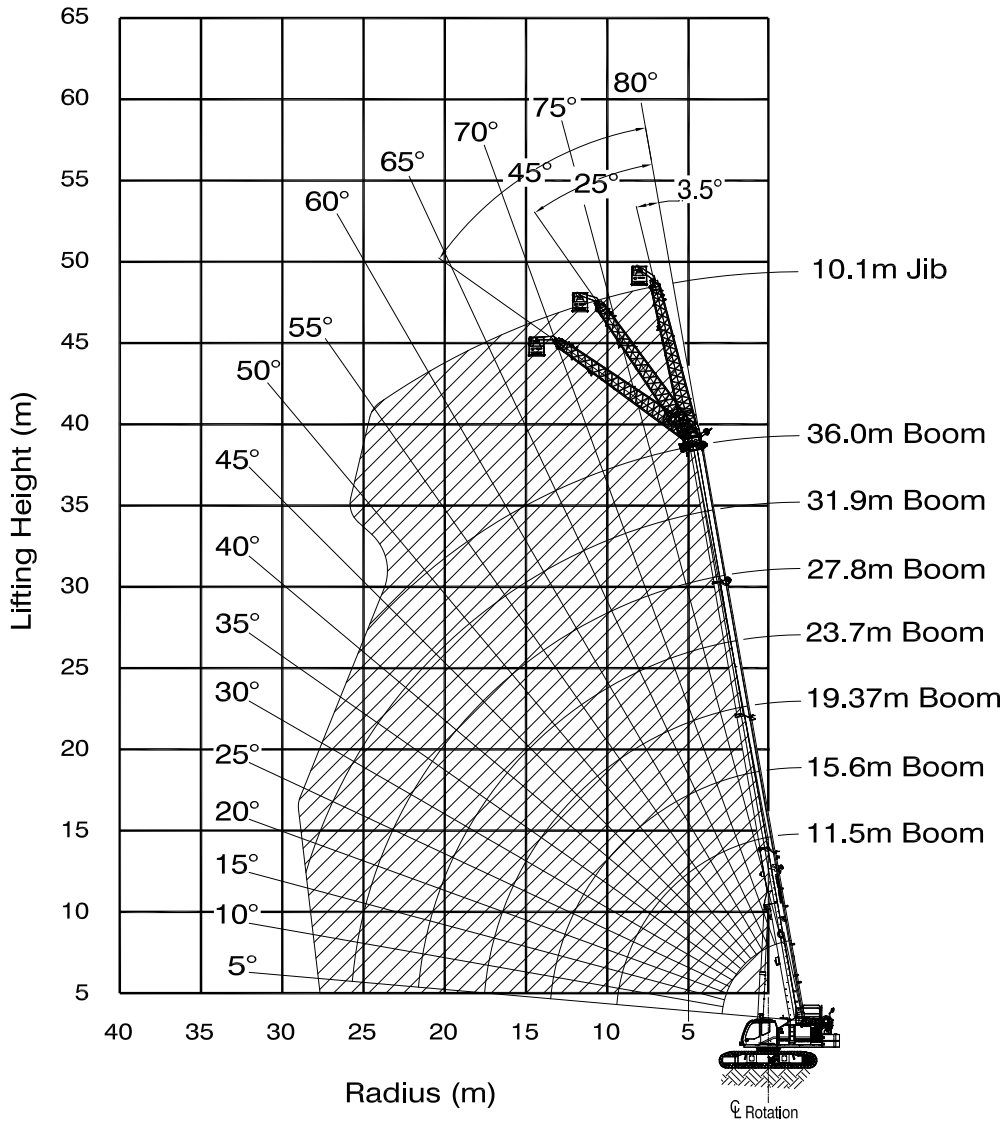

**Notes:**

1. It is permissible to leave the jib section stowed on the boom while operating with Work Platform mounted to the 10.1 m jib.
2. The hook block(s) must be removed when using the Work Platform

**WARNING:** Lifting a load during Work Platform operation is **not** allowed.

**WARNING:** Travelling the crane with person(s) in the Work Platform is **not** allowed.

PLEASE READ, UNDERSTAND, AND FOLLOW THE MANUALS FURNISHED WITH THE CRANE AS WELL AS THE CAPACITY LIMITATIONS AND GENERAL CONDITIONS LISTED BELOW PRIOR TO OPERATION OF THE CRANE. FAILURE TO DO SO MAY RESULT IN AN ACCIDENT.

Performance of this TADANO crane as manufactured by Tadano Mantis Corporation applies only to machines as originally equipped by the manufacturer and in a properly maintained condition. Capacities given are maximum covered by the manufacturer's warranty and are based on a freely suspended load with NO allowance for factors as out-of-level operation (beyond the limits specified on the charts), supporting surface conditions, hazardous surroundings, experience of personnel, etc. The operator shall establish practical working loads based on prevailing operating conditions, such as, but not limited to the above.

The lifting capacities in the structural area are based on DIN 15018 parts 2 and 3 and F.E.M.

The lifting capacities in the stability area are based on DIN 15019 part 2 / ISO 4305 / EN 13000.

Maximum admissible wind velocity for working with telescopic boom and jibs is 32 km/hr. Consult TADANO for ratings at higher wind speeds.

Side pull on boom is extremely dangerous and must be avoided.

DO NOT exceed manufacturers maximum specified reeving.

Boom angle/boom length relationships given are an approximation of the resulted load radius, which should be an accurate measurement.

Boom height dimensions are measured from ground to center of lower boom head sheave.

It is permissible to attempt to telescope boom with a load within the limits of rated capacities. However, boom angle system hydraulic pressure, and/or boom lubrication may affect operation.

It is permissible to travel with loads within the rated capacity of the crane. Travel speeds should be greatly reduced to reflect terrain limitations and minimize dynamic loads applied to the crane structure.

Lifting capacities are shown in kg x 1000.

The weight of load handling devices such as hook blocks, slings, etc., must be considered as part of the load and must be deducted from the lifting capacities.

The lifting capacities for the telescopic boom apply to a crane with no jibs or other optional equipment stowed or mounted on the crane.

The working radius is the horizontal distance from the center of rotation to the center of the freely suspended, non-oscillating load.

The lifting capacities are subject to change without prior notice.

The above remarks are for basic information only and the operator's manual must be consulted before operating this crane. All data and performances refer to the standard crane. The addition of optional and other non-standard equipment may affect the performance of the crane.

Load moment indicating and anti-two block systems are operator aids and must never be used in lieu of job site lift planning calculations by the operator which must take into account ground conditions, weather and all other environmental factors prevailing at the time of the lift. Specifications are subject to change at any time without prior notice. Illustrations and photographs may show optional equipment. Supersedes all previous issues.







 **Lifting your dreams**

**TADANO Mantis Corporation**

1705 Columbia Avenue, Suite 200, Franklin, TN 37064 USA  
Toll-Free: 1-800-272-3325 • Fax: 615-790-6803  
[www.mantiscranes.com](http://www.mantiscranes.com)

**TADANO FAUN GmbH**

Faunberg 2 · 91207 Lauf a. d. Pegnitz · Germany  
Phone: +49-9123-185-0 · Fax: +49-9123-753-20  
[www.tadanofaun.de](http://www.tadanofaun.de) · [info@tadanofaun.de](mailto:info@tadanofaun.de)